

TROTTER-100/150

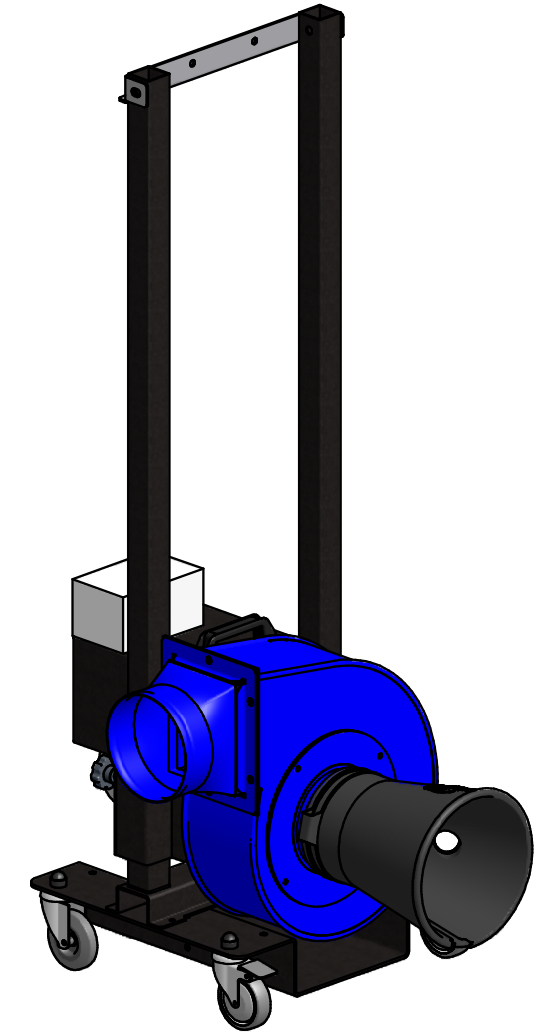

DATI TECNICI			
Pos.	TROTTER-50	TROTTER-100	TROTTER-150
A	150	150	150
B	140	200	200
C	650	820	820
D	230	250	250
E	950	1300	1300
F	320	320	320
G	377	377	377
H	423	423	423
I	400	400	400
M	120	150	150
H LAVORO	230-880 mm	250-1070 mm	250-1070 mm
ALIMENTAZIONE	400V/50Hz	400V/50Hz	400V/50Hz
POTENZA	0.5 Hp	1.0 Hp	1.55 Hp
PORTATA	1000mc/h	1600mc/h	2800mc/h

R02	-	-	-
R01	-	-	-
R00	CREAZIONE DISEGNO		05.06.2014
Rev. N.	Descrizione Modifiche:	Data:	Visto:

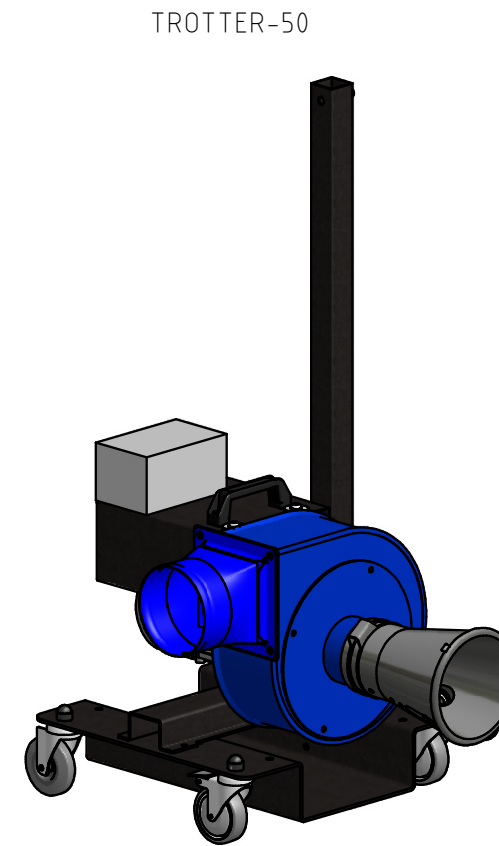

<b>IMPIANTO/MACCHINA:</b> TROTTER					
<b>GRUPPO:</b> COMPLESSIVI E SCHEMI					
<b>PARTICOLARE:</b> SCHEDA TECNICA					
Disegnatore:	Data:	Scala:	Codice / Disegno N.	Rev. N.	Visto:
Luca Giannini	05/06/2014	-	<b>TROTTER</b>	<b>R00</b>	